

- 1.) REMOVE TUBING BY UNSCREWING THE NUT/FERRULE FROM THE FITTING AND REMOVE THE HANDLE OR MOTOR FROM PUMP.
- 2.) TURN THE ACME ROD (A) AT THE END OF THE PUMP CLOCKWISE TO REMOVE THE OIL INSIDE THE PUMP.
- 3.) REMOVE ALL PUMP SCREWS (B).
- 4.) REMOVE THE PUMP HOUSING (C).
- 5.) REMOVE THE END BLOCK BY USING A RUBBER Mallet (D); HOLD THE PUMP TUBES WHILE DOING THIS.



MONARCH HYDRAULICS, INC.

Dyna-Lit[®] Group

1363 MICHIGAN ST. NE
GRAND RAPIDS, MI 49503

PHONE: (616) 458-1306
FAX: (616) 458-1616

SAVED AS: RPCINSTR
REV: 6/05

BY: BJW

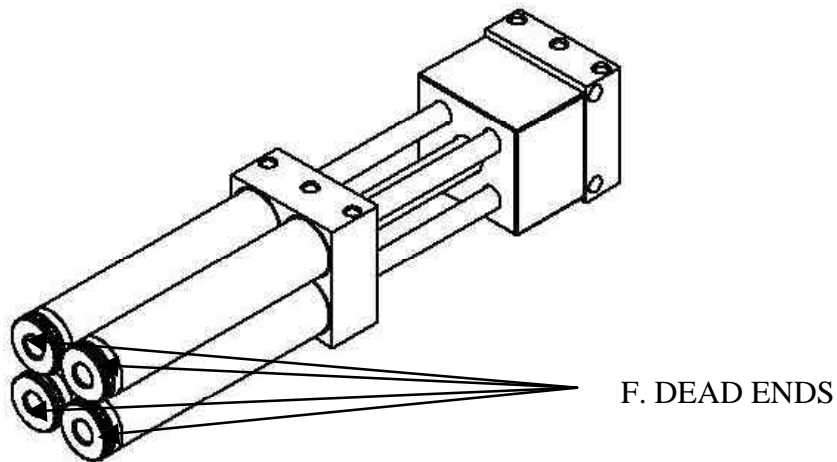
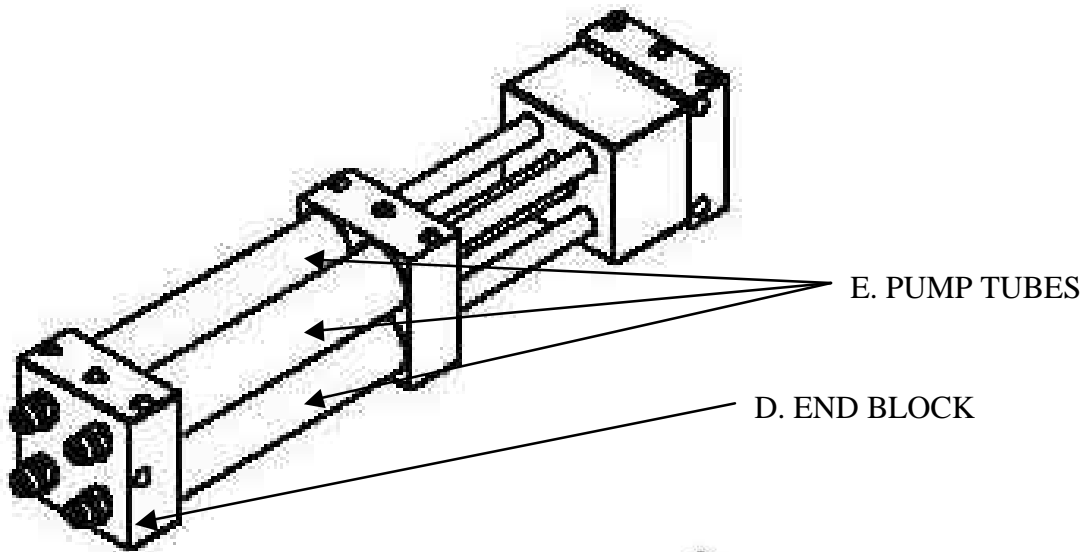

- 6.) REMOVE THE PUMP TUBES (E).
- 7.) REMOVE THE DEAD ENDS (F); SOME MAY BE ON THE PUMP TUBES OR ON THE END BLOCK.
- 8.) REMOVE ALL OF THE O-RINGS FROM THE DEAD ENDS AND ALSO THE T-SEALS FROM THE PUMP PISTONS.

CAUTION: BE CAREFUL NOT TO DAMAGE THE DEAD ENDS OR THE PUMP PISTONS.



MONARCH HYDRAULICS, INC.

Dyna-Lit® Group

1363 MICHIGAN ST. NE
GRAND RAPIDS, MI 49503

PHONE: (616) 458-1306
FAX: (616) 458-1616

SAVED AS: RPCINSTR
REV: 6/05

BY: BJW

- 9.) CLEAN ALL OF THE DEAD ENDS, PISTONS, PUMP TUBES, AND THE END BLOCK WITH A MILD CLEANER TO REMOVE ANY DEBRIS.
- 10.) PLACE THE NEW O-RING'S ONTO THE DEAD ENDS BY ROLLING THEM INTO THE GROVE.
- 11.) PLACE THE RUBBER SEAL OVER EACH OF THE PISTONS AND THEN PLACE THE BACK UP RINGS (CARDBOARD LIKE MATERIAL) ABOVE AND BELOW THE RUBBER SEAL.
- 12.) TO ASSEMBLE, USE A PETROLEUM JELLY OR EQUIVALENT TO THE ENTIRE T-SEALS FOR LUBRICATION. SLIDE THE PUMP TUBES OVER THE PISTONS UNTIL THEY BOTTOM OUT. TAKE EACH OF THE DEAD ENDS WITH THE O-RINGS INSTALLED AND ALSO LUBRICATE THEM WITH THE PETROLEUM JELLY AND SET THEM ON TOP AND IN LINE WITH THE PUMP TUBES AND LIGHTLY HAMMER THEM ON WITH A RUBBER Mallet MAKING SURE NOT TO CUT THE O-RING. AFTER ALL ARE INSTALLED TAKE THE END BLOCK AND SET IT ON THE LUBRICATED DEAD ENDS (MAKE SURE THE THREADED HOLES LINE UP WITH THE OTHER THREADED BLOCKS) AND PRESS IT DOWN ONTO THE DEAD ENDS. INSPECT TO MAKE SURE THAT NONE OF THE O-RINGS HAVE BEEN CUT. REPLACE THE PUMP HOUSING AND ALL OF THE SCREWS INTO THE HOUSING.
- 13.) LIFT CYLINDER PROCEDURE: REMOVE TUBING BY UNSCREWING THE NUT/FERRULE FROM THE FITTING. REMOVE THE SNAP RING (G) AND PULL OUT THE CYLINDER (H). WITH THE CYLINDER REMOVED PULL ON THE ROD (J) WHILE HOLDING ONTO THE LIFT TUBE (K) UNTIL THE LIVE END (L) IS PULLED OUT ALONG WITH THE ROD (A TUGGING ACTION WILL HELP IN DOING THIS). REMOVE THE T-SEAL FROM THE PISTON. INSTALL THE NEW ONE ONTO THE PISTON THE SAME AS THE OTHER T-SEAL BY FIRST PUTTING THE RUBBER SEAL ONTO THE PISTON AND THEN PLACE THE BACK UP RINGS ABOVE AND BELOW IT. REPEAT THIS PROCESS FOR ALL OF THE LIFT CYLINDERS.
- 14.) TO ASSEMBLE THE CYLINDER AGAIN USE A PETROLEUM JELLY AND LUBRICATE THE T-SEAL, PUSH THE ROD INTO THE TUBE AND THEN GENTLY PUSH THE LIVE END BACK INTO PLACE.



MONARCH HYDRAULICS, INC.

Dyna-Lit[®] Group 1363 MICHIGAN ST. NE
GRAND RAPIDS, MI 49503

PHONE: (616) 458-1306
FAX: (616) 458-1616

SAVED AS: RPCINSTR
REV: 6/05

BY: BJW

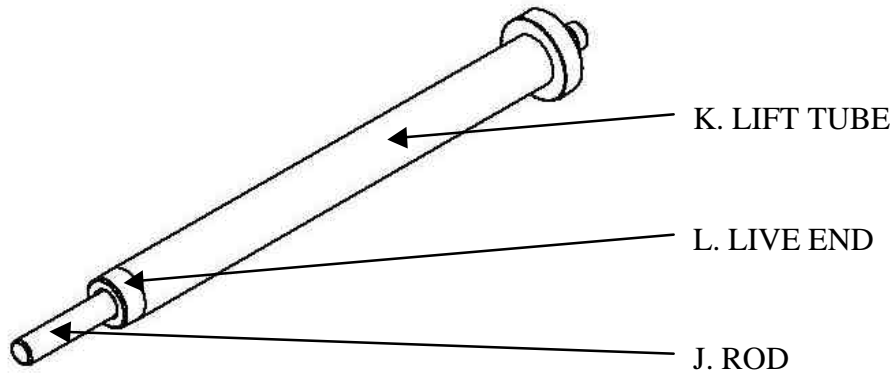
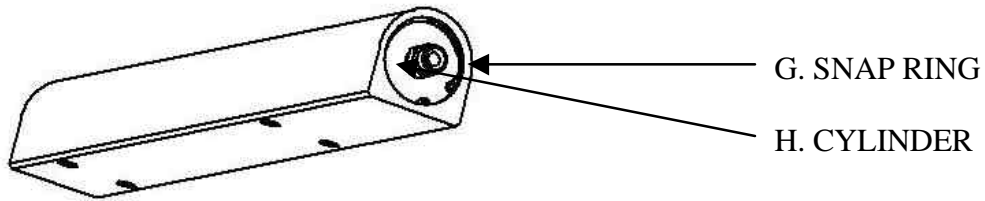

15.) TO REFILL THE SYSTEM REFER TO THE RECHARGE INSTRUCTIONS.



MONARCH HYDRAULICS, INC.

Dyna-Lift® Group

1363 MICHIGAN ST. NE
GRAND RAPIDS, MI 49503

PHONE: (616) 458-1306
FAX: (616) 458-1616

SAVED AS: RPCINSTR
REV: 6/05

BY: BJW